

PERFORMANCE

| | | |
|--|----------------------|----------------------|
| Vehicle model | APOLLO 25.6 R | APOLLO 25.6 |
| Maximum capacity | 2500 kg (5512 lb) | 2500 kg (5512 lb) |
| Maximum lifting height | 5,78 m (19 ft) | 5,78 m (19 ft) |
| Maximum horizontal extension | 3,25 m (10,7 ft) | 3,25 m (10,7 ft) |
| Fork swiveling angle | 129° | 129° |
| Pull-out force | 7600 daN (17085 lbf) | 7600 daN (17085 lbf) |
| Towing force | 3400 daN (7644 lbf) | 4400 daN (9892 lbf) |
| Maximum climb angle | 40% | 40% |
| Unladen weight | 4800 kg (10582 lb) | 4900 kg (10803 lb) |
| Max speed (referred to wheels with maximum permitted diameter) | 23 km/h (14,3 mph) | 30 km/h (18,6 mph) |

BOOM

| | | |
|-------------------|---------------|-------------|
| Vehicle model | APOLLO 25.6 R | APOLLO 25.6 |
| Lifting | 8,8 s | 7,8 s |
| Descent | 4,1 s | 4,1 s |
| Extension | 6,1 s | 6,1 s |
| Retraction | 3,4 s | 3,4 s |
| Forward swiveling | 3,5 s | 3,5 s |
| Reverse swiveling | 2,2 s | 2,2 s |

ENGINE

| | | |
|-------------------------------------|---|---|
| Vehicle model | APOLLO 25.6 R | APOLLO 25.6 |
| Brand | Kubota | Kubota |
| Nominal power | 36,5 kW (49 HP) | 55,4 kW (74 HP) |
| @rpm | 2700 rpm | 2600 rpm |
| Operation | 4-stroke | 4-stroke |
| Injection | Mechanical | Mechanical |
| Number and arrangement of cylinders | 4, Vertical in line | 4, Vertical in line |
| Displacement | 2615 cm ³ (160 in ³) | 3331 cm ³ (203 in ³) |
| Emission standard | Stage IIIA/Tier 3 | Stage IIIA/Tier 3 |
| Cooling system | Liquid | Liquid |
| Intake | Natural | Turbo compressor |

DIFFERENTIAL AXLES

| | | |
|------------------|--|---|
| Vehicle model | APOLLO 25.6 | APOLLO 25.6 R |
| Type of axles | 2 steering, with 4 planetary reduction gears | 2 steering, with 4 epicycloidal reduction gears |
| Type of steering | 4 wheels / transversal / 2 wheels | 4 wheels / transversal / 2 wheels |
| Front axle | Rigid | Rigid |
| Rear axle | Swinging | Swinging |
| Service braking | Oil bath on front axle | Oil bath on front axle |
| Parking braking | Negative actuation with electrical control | Negative actuation with electrical control |

HYDRAULIC SYSTEM

| | | |
|-------------------------|--|--|
| Vehicle model | APOLLO 25.6 R | APOLLO 25.6 |
| Hydraulic pump type | Gear pump for power steering and movements | Gear pump for power steering and movements |
| Hydraulic pump capacity | 70 L/min (18,5 gal/min) | 80 L/min (21,1 gal/min) |
| Max. operating pressure | 23,0 MPa (3336 psi) | 23,0 MPa (3336 psi) |
| Distributor control | Proportional 4in1 Joystick | 4in1 proportional Joystick |

REFUELING

| | | |
|--------------------------|--------------------|--------------------|
| Vehicle model | APOLLO 25.6 R | APOLLO 25.6 |
| Hydraulic system (total) | 70,0 L (18,49 gal) | 70,0 L (18,49 gal) |
| Fuel tank | 80,0 L (21,13 gal) | 80,0 L (21,13 gal) |

TRANSMISSION

| | | |
|-------------------|---|---|
| Vehicle model | APOLLO 25.6 R | APOLLO 25.6 |
| Transmission type | Single speed Hydrostatic transmission with variable displacement pump | Single speed Hydrostatic transmission with variable displacement pump |
| Hydraulic motor | Hydrostatic with continuous automatic adjustment | Hydrostatic with continuous automatic adjustment |
| Reversal | Electro-Hydraulic | Electro-Hydraulic |
| Inching | With hydraulic pedal for controlled forward movement | With hydraulic pedal for controlled forward movement |

TIRES

| | | |
|----------------|---------------|-------------|
| Vehicle model | APOLLO 25.6 R | APOLLO 25.6 |
| Standard tires | 12x16.5" | 12x16.5" |
| Optional tires | 12x18" | 12x18" |

DIMENSIONS

| Vehicle model | APOLLO 25.6 R | APOLLO 25.6 |
|---------------|--------------------|--------------------|
| A | 270 mm (10,6 in) | 270 mm (10,6 in) |
| B | 985 mm (38,8 in) | 985 mm (38,8 in) |
| C | 2350 mm (92,5 in) | 2350 mm (92,5 in) |
| D | 765 mm (30,1 in) | 765 mm (30,1 in) |
| F | 3535 mm (139,2 in) | 3535 mm (139,2 in) |
| G | 4125 mm (162,4 in) | 4125 mm (162,4 in) |
| H | 1950 mm (76,8 in) | 1950 mm (76,8 in) |
| I | 1850 mm (72,8 in) | 1850 mm (72,8 in) |
| L | 1500 mm (59,1 in) | 1500 mm (59,1 in) |
| M | 1850 mm (72,8 in) | 1850 mm (72,8 in) |
| P | 1460 mm (57,5 in) | 1460 mm (57,5 in) |
| Q | 3555 mm (140 in) | 3555 mm (140 in) |
| S | 1433 mm (56,4 in) | 1433 mm (56,4 in) |
| T | 200 mm (7,9 in) | 200 mm (7,9 in) |

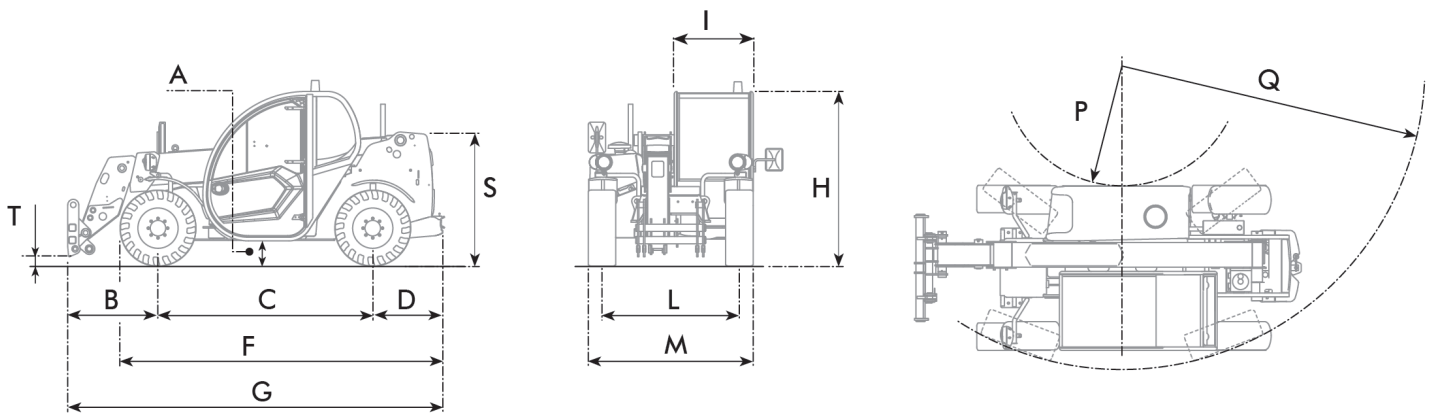

MAX 2,5 t

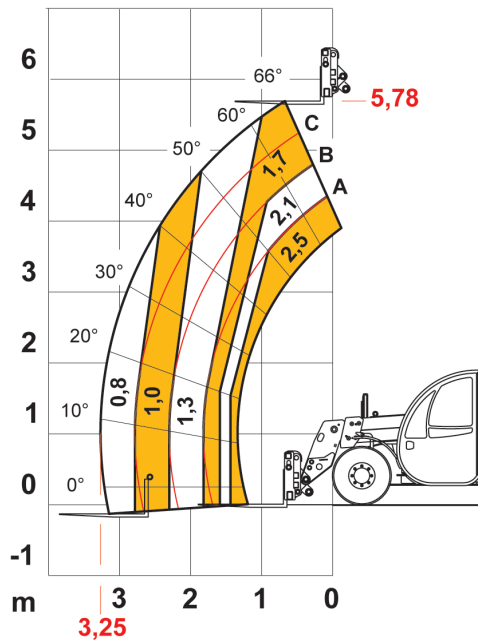

AXB1377



EN1459

25.6